

# A Bifurcated Beam Opto-electronic Camera for Investigation of Phenomena Associated with Fast Rising Arc Voltage.

**R. E. Brown, P. M. McEwan,**

R E Brown  
8 Oak Grove  
Thurcroft  
ROTHERHAM  
South Yorkshire S66 9EZ  
Email: bob.brown@bun.com

P M McEwan,  
Department of Design,  
Faculty of Technology and Information Systems  
Brunel University  
Egham, Surrey, UK.  
TW20 0JZ  
Email: pmcewan@iee.org

## Abstract

Recent technical advances in sensitive opto-electronic sensors have enabled the development of optical instruments for investigating arcing ignition and other phenomena related to fast-rising arc voltage transients, typically occurring during disintegration of fuse wire elements carrying short circuit fault currents. This paper presents the design, testing and performance attributes of an experimental 'black box' slit aperture camera, based on such a sensor, which is able to operate at approximately 30000 frames/second (f/s) in bifurcated beam, two-sensor quadrature mode. Also presented are evaluations of the camera images compared with other forms of transient and historical data captured during the disintegration of high breaking capacity (HBC) wire fuse elements, which indicate good cross-correlation and acuity of arc ignition phenomena. The evaluations of the data indicate that the camera is capable of distinguishing the intensity, position and dimensions of arc ignition and elongation during disintegration of wire elements within a 10  $\mu$ s time frame, which are validated by cross-correlation with the attributes of extant fulgurites obtained using a fast-acting synchronized 'crowbar' switched test circuit.

## 1. Introduction

Visual observation of arcs in motion, invariably, provides better understanding of arcing behaviour. Observation of arc formation and motion within hermetic enclosures, such as compacted sand-filled high breaking capacity (hbc) fuse types, pose special problems

because of the speed (typically  $<10\mu$ s) of individual arc ignitions, the hazards of measurements and the invasiveness of arc data capture techniques. Consequently, the phenomena of fuse element disintegration and the effect of confinement on this process remain largely unresolved according to Wolny [1], and hence are still a principal focus of research which may be supported by the bifurcated beam opto-electronic camera and data capture methodology presented and discussed here.

Accordingly, novel very fast measurement techniques have been devised to capture arc ignition data to represent the various parameters of the current interruption process in hbc experimental fuse arrangements, which, broadly, divide into invasive and non-invasive 'transient voltage/current' and 'fossil' data capture techniques.

The principal exponents of the invasive fuse arc data capturing techniques are Kleen [2], and Daalder & Schreues [3] who, independently, used multiple voltage probes inserted through the walls of fuse cartridges. The probes were distributed along fuse elements such that the probes became immersed, at some stage, in the extended arcs.

Non-invasive flash x-ray photography techniques, developed by Arai [4], were used to provide images of the break-up of wire fuse elements. Non-invasive measures of arc light emissions have also been captured during element disintegration by Gomez [5] Barrow and Howe [6] and Cheim [7] using several optical fibres in close proximity to elements. Additionally, images of fuse element disintegration and arcing in wires suspended in air have been captured by Baxter [8] using a

fast 'cine' camera, Vermij [9] using a streak camera and Brown [10] using a fast (2000f/s) video camera.

The principal 'fossil' arc investigation techniques, primarily, involve obtaining data from sintered sand-element arc track remnants extant within hbc fuse filler after arcing has been terminated by natural or forced current-commutation of the fuse current. The remnants, referred to as fulgurites, permit measures of arc length, arc energy, the rate of element erosion [11] and arc elongation [12].

The principal design requirement for the proposed opto-electronic camera was to capture individual arc ignitions and cross-correlate arc light emission, arc voltage/current transients and fossil attributes of progressive arc ignitions and extended arc burning in hbc fuse wire and notched element types during current interruption periods, corresponding to short-circuit test duties for fast-acting hbc fuses, such as exhibited by thick metal conductive film substrate fuse types.

## 2. Opto-electronic Camera Design and Data Capture Techniques.

The proposed opto-electronic camera was designed specifically for light image capture of multiple arc ignitions occurring

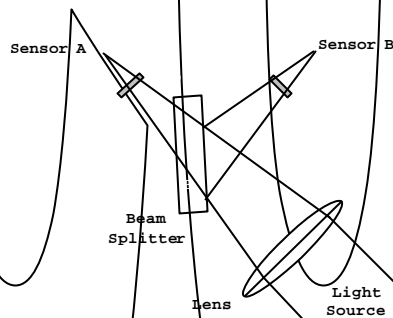

Fig 1. Opto-electronic camera optical system.

along wires and hbc fuse elements within a time period 10 $\mu$ s~150 $\mu$ s and to be able to capture extended arcing within periods in excess of 5ms.

The camera's optical system comprises a planar convex lens, a beam splitter and two light sensors; optically aligned within an opaque black box, figure 1. The arc light source converges onto the two light sensors after passing through a slit aperture and beam splitter. The beam splitter enables two light image captures per integration cycle and a doubling of the capture speed of the camera.

The camera's design was based on the Texas Instruments 8 pin DIL optical sensor device TSL 1401, comprising 128 'pixels' with individual photo diode; associated charge amplifier and pixel data hold circuitry. Photo current from a pixel diode, when integrated, outputs a voltage indicator of the light energy falling onto the pixel in a predefined integration period. The sensor's pixel data hold function, additionally, provides simultaneous start and stop time instances for all pixels.

Figure 2 shows a simplified block diagram of the camera and the interconnections between the fuse test facility, optical system, camera control electronics and two oscilloscopes for capturing the image attributes of the bifurcated arc light source.

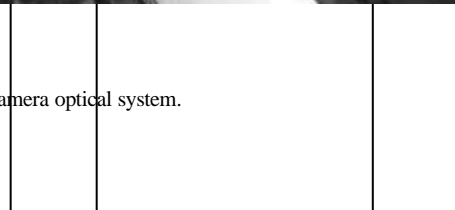

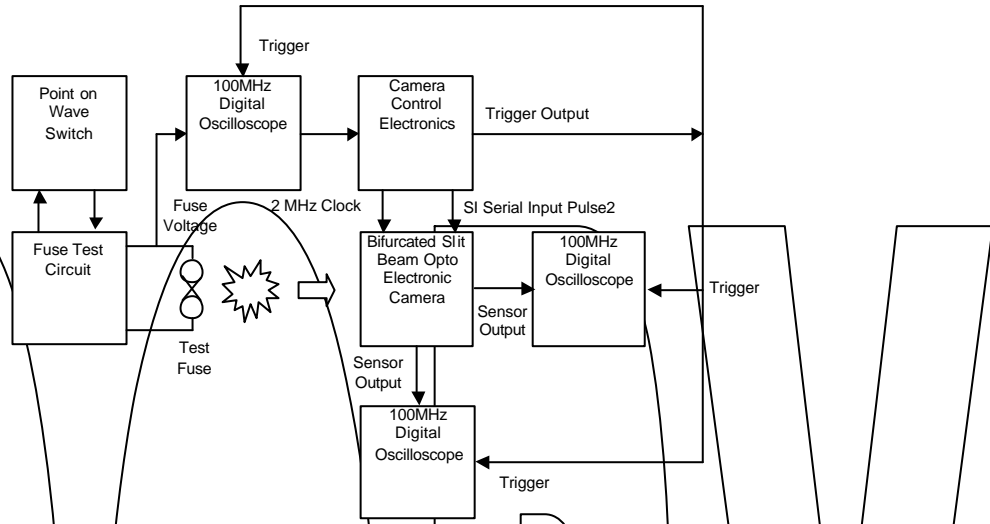

Fig. 2. Schematic diagram of opto-electronic camera control, optical system and fuse test circuit.

At the beginning of the integration period, a pre-discharged (sampling) capacitor connects to each of the integrators through an analogue switch. The output and reset of the pixel integrators are controlled by a 128-bit shift register and reset logic. The sensor output sequences are initiated by the application of the (SI) serial input pulses. These signals are derived from a comparator, set to latch at the onset of disintegration of the fuse element, which is then inputted to the time delay circuit of each beam image trigger circuit to give time shifted SI series for each beam by manual pre-set adjustment. This dual delay configuration

enables capture of two pre-settable time-differentiated image attributes by the camera, with reference to a pre-settable test circuit time-phase reference as indicated in the pulse timing diagram of figure 3. Each oscilloscope displays both temporal and light intensity attributes of arc ignition at separate pre-settable intervals in the range  $1\mu\text{s}$ ~ $64\mu\text{s}$ . A thyristor 'crow bar' switch is configured so that it is able to divert the test circuit current from the fuse test sample within  $5\mu\text{s}$  of the instant of an image capture to permit momentary capture of fulgurites [12].

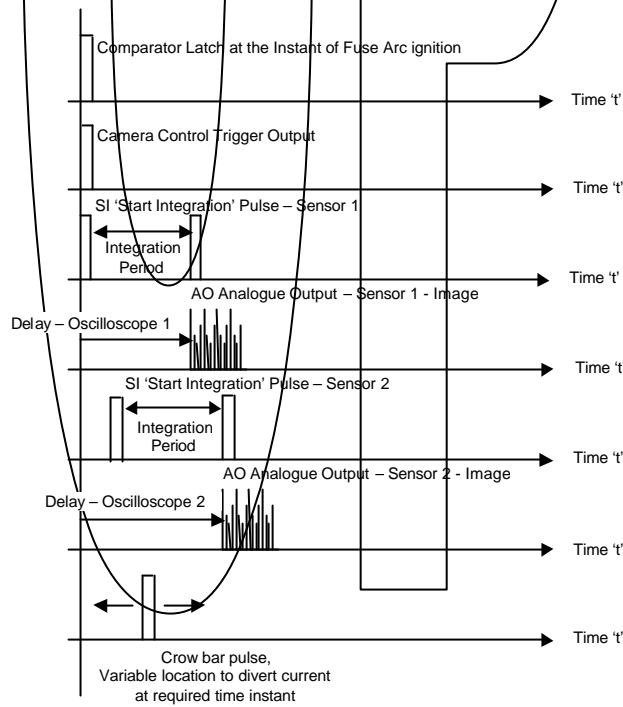

Figure 3 Diagram indicating control pulse (SI) and camera image (AO) capture instances

### 3. Experimental arrangement for image capture of arc ignitions in wire and notched element hbc fuses

Special robust experimental enclosures were devised to detect arc ignitions in fuse elements within compacted silica filler to ensure good acuity of arc light emission and protection of the camera lens from expelled arc products. The wire and notched fuse element samples were bonded to glass slides as shown in figure 4, hence the glass slides acted as a window, arc shield and fuse substrate base. The elements were pressed against the glass substrate by the filler, which was compacted by vigorous mechanical vibration.

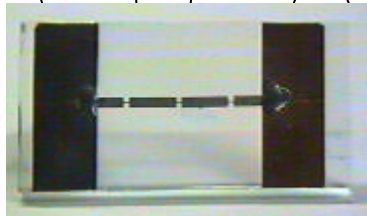

Fig 4i Examples of the wire and a notched fuse element window/substrate test samples used in experimental investigations.



Fig 4ii Fuse test samples and test enclosure showing glass substrate-mounted fuse wire and elements with and without filler

### 4. Camera calibration methods and techniques

Special camera calibration procedures and hardware were devised to validate the camera attributes. Testing procedures were also developed to validate the transient performance of the camera.

The calibration and testing set-up consisted of a homogenous light source comprising a columnar light box with a 650W white light source and a small hole on one side of the box, figure 5., which was positioned on the same horizontal axis to the light aperture of the camera such that the light radiating through the hole entered the camera through a 25mm ( $l$ )  $\times$  0.2mm ( $w$ ) slit and focused onto the two light sensors. The alignments of each sensor were calibrated relative to the horizontal axis

of the optical system by capturing the sensor outputs when triggered using ramp voltage latch techniques and were monitored until the responses of all pixel outputs were within a range of  $\pm 0.1$  volts (3% nominal full scale deflection). The results from testing confirmed that the pixel voltage output-integration time relationship was linear.

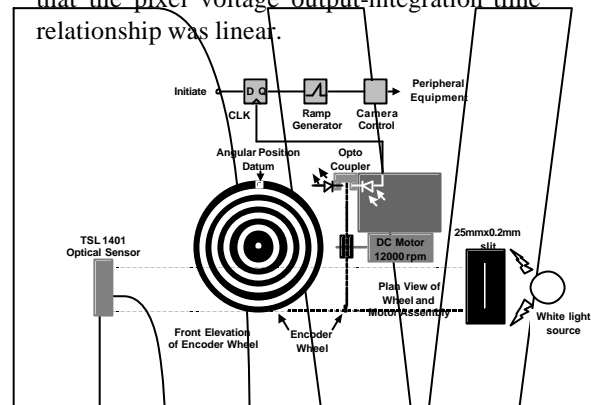

Fig. 5. Patterned encoded wheel and simplified block diagram of camera timing test arrangements.

Validation of the transient response necessitated devising a series of patterned encoded wheels, figure 6i. These wheels were positioned against the camera aperture and rotated at 12000 rpm with the horizontal axes of the wheel and the optical system aligned. The wheels were pattern encoded with 25 alternating transparent and opaque rings, where the centre ring of a wheel is aligned with the vertical axis of the optical system. The angular position datum is referenced on each wheel by a transparent window in the opaque outer ring, which, when detected by an opto-coupler, initiates camera data capture. An example of the normalized output of the sensors is shown in figure 6ii.

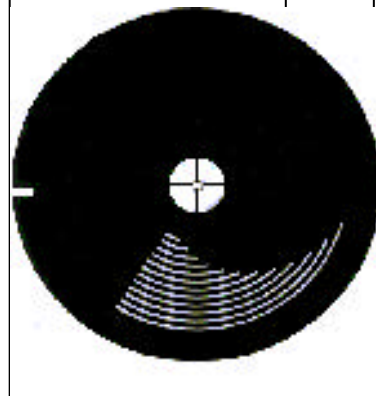

Fig. 6i Patterned-encoded wheel, typical of sequential arc ignition

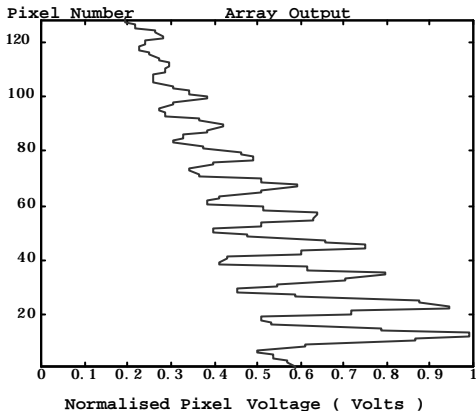

Fig. 6ii Normalised sensor output with integration time = 1.5ms

Figs 6 Example of a simulated sequential arc ignition pattern-encoded wheel and corresponding sensor output

## 5. Camera commissioning

Commission tests included setting the range of the sensor output (0~2volts) within the range of the maximum light intensity radiated from the fuse element to determine the camera's noise limitations and the degree of image lag, ie. the amount of trapped data in successive camera images.

## 6. Time correlation and fuse current commutation techniques

Time correlation of data representing arc ignition phenomena in fuse elements was achieved by synchronizing the capture of transient data relative to a single time event instant, the 'event' being the latching of the opto-electronic camera comparator whereby all cross-correlation data from each source was verified.

## 7. Results of Temporal and spatial correlation of arc ignition measurements

Figure 7 shows the time-correlated attributes of two-beam mode camera operation over one integration cycle for a single test of a copper wire sample. The corresponding sensor data sets are captured on two oscilloscopes; 20 $\mu$ s after the arc voltage is detected by the first oscilloscope and after an interval of 10 $\mu$ s by the second, figure 6i. Figure 7ii indicates the instant of 'crow-barring' the circuit current after a further interval of 5 $\mu$ s, resulting in a 35 $\mu$ s time frame for the arc voltage and extant fulgurite attribute, immediately following current commutation. The results, figure 7, show that the pixel data correlates the

positions, intensities and widths of arcs which is evidenced in the size and positions of sintered remnants in the corresponding fulgurite. The arc voltage attribute indicates the instances the arc voltages appear and contribute to the instantaneous value. Furthermore, correlated analysis of multiple arc ignitions and momentary fulgurite attributes can be achieved by repetitive testing of identical fuse samples at different 'crowbar' switch time settings [13].

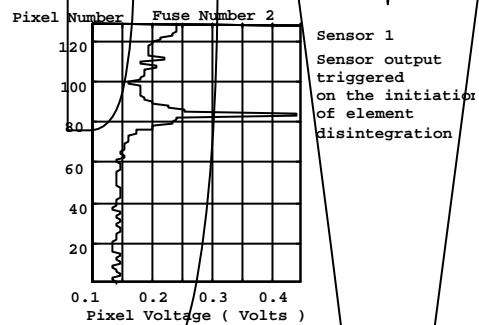
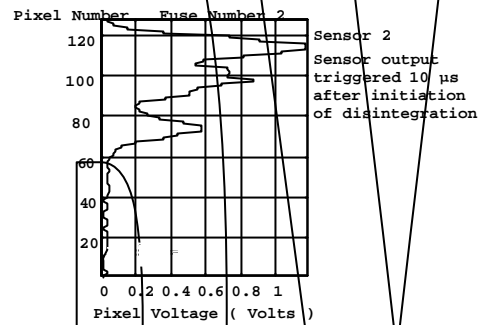

Fig 7i Sensor outputs delayed by 10 $\mu$ s and fuse fulgurite

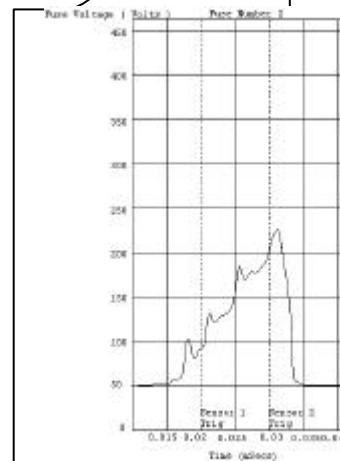

Fig. 7ii Fuse voltage oscillogram – with current 'crow-barred' 5 $\mu$ s after Sensor 2 triggered

Fig. 7 Two-beam mode (10 $\mu$ s sensor-delayed) opto-electronic camera image & fuse fulgurite attributes and arc voltage oscillogram for single test on fuses wires.

## 8. Conclusions

The presented results demonstrate that current opto-electronic pixel array chip technology is sufficiently advanced to enable the design of accurate and responsive optical systems that are fast enough to enable investigation and data capture of fuse element break up, arc ignition and arc extension phenomena in hbc fuse wires and notched type elements in both the spatial and temporal domains.

The presented black box slit aperture camera design, together with the proposed data capture and test techniques, demonstrate good data cross-correlation of the camera arc light source attributes with respective conventional circuit temporal and spatial arc disposition attributes.

Use of the camera in conjunction with a p.o.w switch demonstrated good camera image acuity for individual arcs of 10 $\mu$ s durations and that good acuity of ignition attributes in the 1 $\mu$ s domain is feasible.

The results show that the camera operates at approximately 30,000 f/p in two-beam repetitive frame data-capture mode and at 15,000 f/s in corresponding single-beam mode and, that in single-shot mode, the camera has an equivalent speed, for a 10 $\mu$ s duration data capture sets, of 100,000 f/s and 1000,000 f/p for 1 $\mu$ s duration data sets.

Finally, the hbc fuse data capture results, Fig. 7, show that the camera data sets, clearly, distinguish the intensity, position and dimensions and incidence of individual, successive, arc ignitions, which correlate precisely to the attributes of respective fulgurite remnants. The proposed camera, therefore, provides new insights into fundamental fuse element disintegration phenomena and is considered to be a useful tool for determining the fuse element design constraints of arc formation for varying fuse short-circuit fault conditions, element shape and surrounding fuse media.

## 9. References

- [1] WOLNY, A., 'Effect of Fuse Element Confinement on the Rate of Rise of Fuse Arc Ignition Voltage', 6<sup>th</sup> International Conference on Electrical Fuses and their Applications, September 1999, Torino, Italy, pp 135-139.
- [2] KLEEN, W., 'Uber den durchgang der elektrizitat durch matallische Haardrahte', *Ann.Phys.*, 1931, **11** (5), pp579 - 605.
- [3] DAALDER, J.E., SCHREURS, E.F., 'Arcing phenomena in high voltage fuses.' EUT Report 83-E-137, Department of Electrical Engineering, Eindhoven University of Technology, 1983.
- [4] ARAI, S., 'Deformation and disruption of silver wires', International Conference on Electrical Fuses and their Applications, April 1976, Liverpool, U.K., pp50-58.
- [5] GOMEZ, J. C., 'HBC fuse models based on fundamental arcing mechanisms', Ph.D. Thesis, Sheffield Hallam University, UK, September 1994.
- [6] BARROW, D.R., HOWE, A.F., 'The use of Optical Spectroscopy in the Analysis of Electrical Fuse Arcing', 4th International Conference on Electrical Fuses and their Applications, September 1991, Nottingham, U.K., pp 221 -225.
- [7] CHEIM, L.A.V., HOWE, A.F., 'Spectroscopic Observations of High Breaking Capacity Fuse Arcs'. *IEE Proc.-Sci. Meas. Technol.*, 1994, **141** (2), pp 123-128.
- [8] BAXTER H.W., Electric Fuses, ERA Report GT/224, ERA Technology Limited, Cleeve Road, Leatherhead, Surrey. KT22 75A
- [9] VERMIJ, L., 'The voltage across a fuse during the current interruption process', *IEEE Transactions on Plasma Science*, Dec. 1980, **PS-8** (4), pp460-468.
- [10] BROWN, R. E., 'Investigation of Disintegration and Arcing in Electric Fuses', Ph.D. Thesis, Sheffield Hallam University, UK, January 2000.
- [11] GNANALINGHAM, S., WILKINS, R., 'Digital Simulation of Fuse Breaking Tests'. *I.E.E. Proc.* **127 C** (6), November 1980.
- [12] DOLEGOWSKI, M., 'Calculation of the Course of the Current and Voltage of a Current Limiting Fuse'. International Conference on Electric Fuses and their Applications, April 1976, Liverpool U.K., pp218.
- [13] BROWN, R. E., MCEWAN, P.M., 'Opto-electronic camera for non-invasive investigation of arcing in short-circuit current-carrying conductors and HBC fuse elements', *IEE Proc.-Sci. Meas. Technol.*, Accepted for publication Feb. 2003.